

The μm Precise Inspection Machine for
Cutting Edge Preparation and Surface Finish

ZOLLER
expect great measures

μm Focus

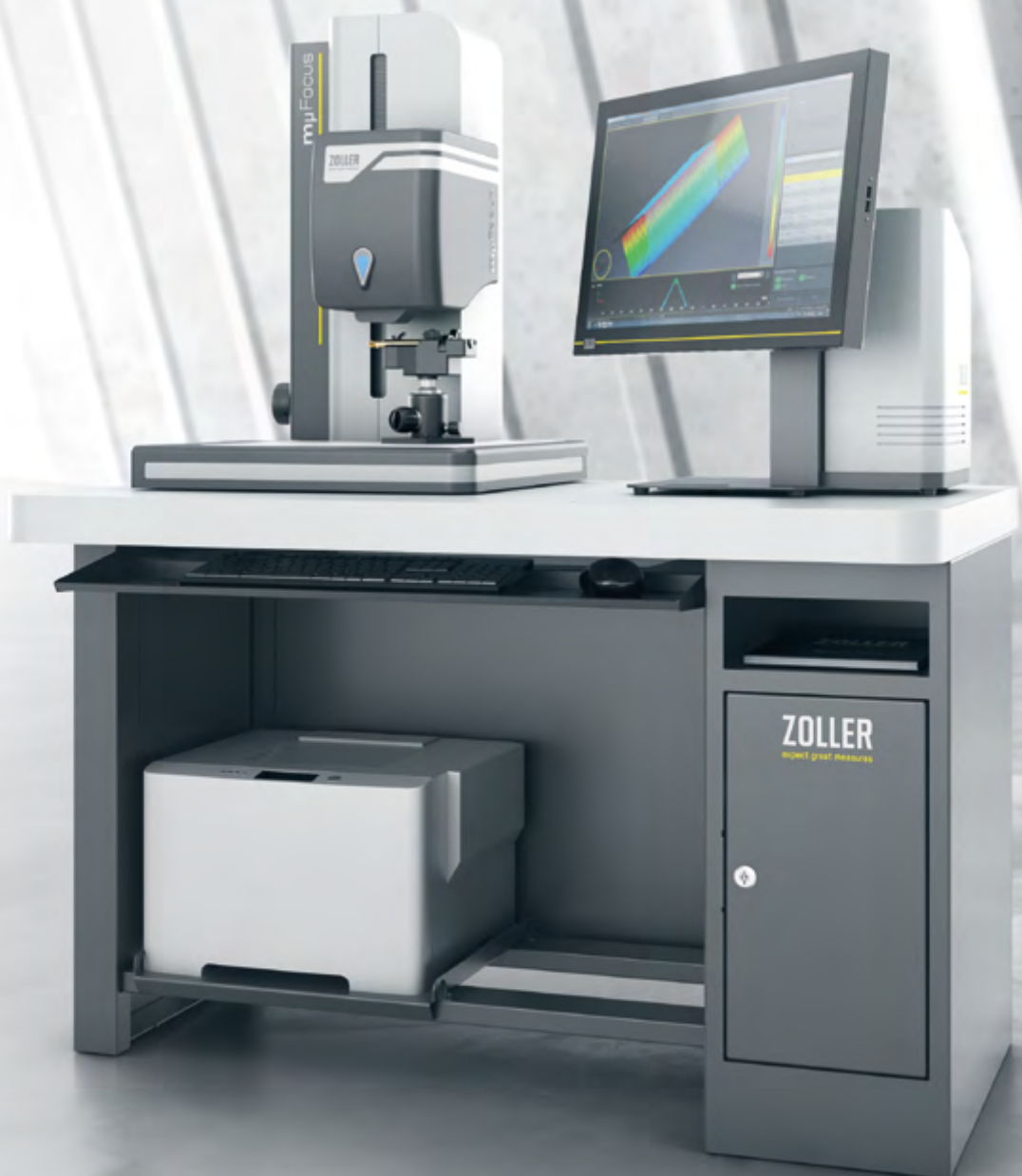
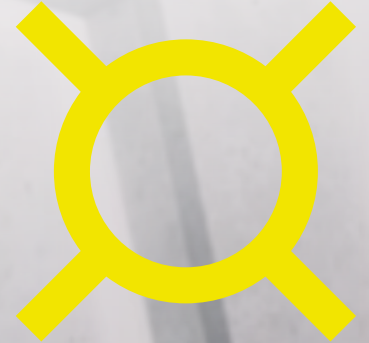

Focused on perfection

You want to produce the perfect cutting edge – one that ensures a long tool life, minimal wear, optimal chip formation, and precision workpiece processing, thereby significantly lowering costs for production.

Achieve your goals with high-precision tool geometry and optimal surface textures customized to your specific application. If you want to ensure exact, standardized quality in your tool development, then the ZOLLER » μ Focus« inspection machine is the right choice for your needs.

» μ Focus« uses non-contact measurement procedures to determine the surface roughness and cutting edge preparation of your tool, down to the μm . Use the ZOLLER » μ Focus« to create fully optimized tools.

» μ Focus«





Stable Values

Whether you use the ZOLLER » μ Focus« in your inspection room or production environment, your results will not be affected. You will always receive the highly precise measured values you need. Its robust design helps the machine guarantee outstanding measuring technology performance even if placed between the tool shelves and CNC machines.

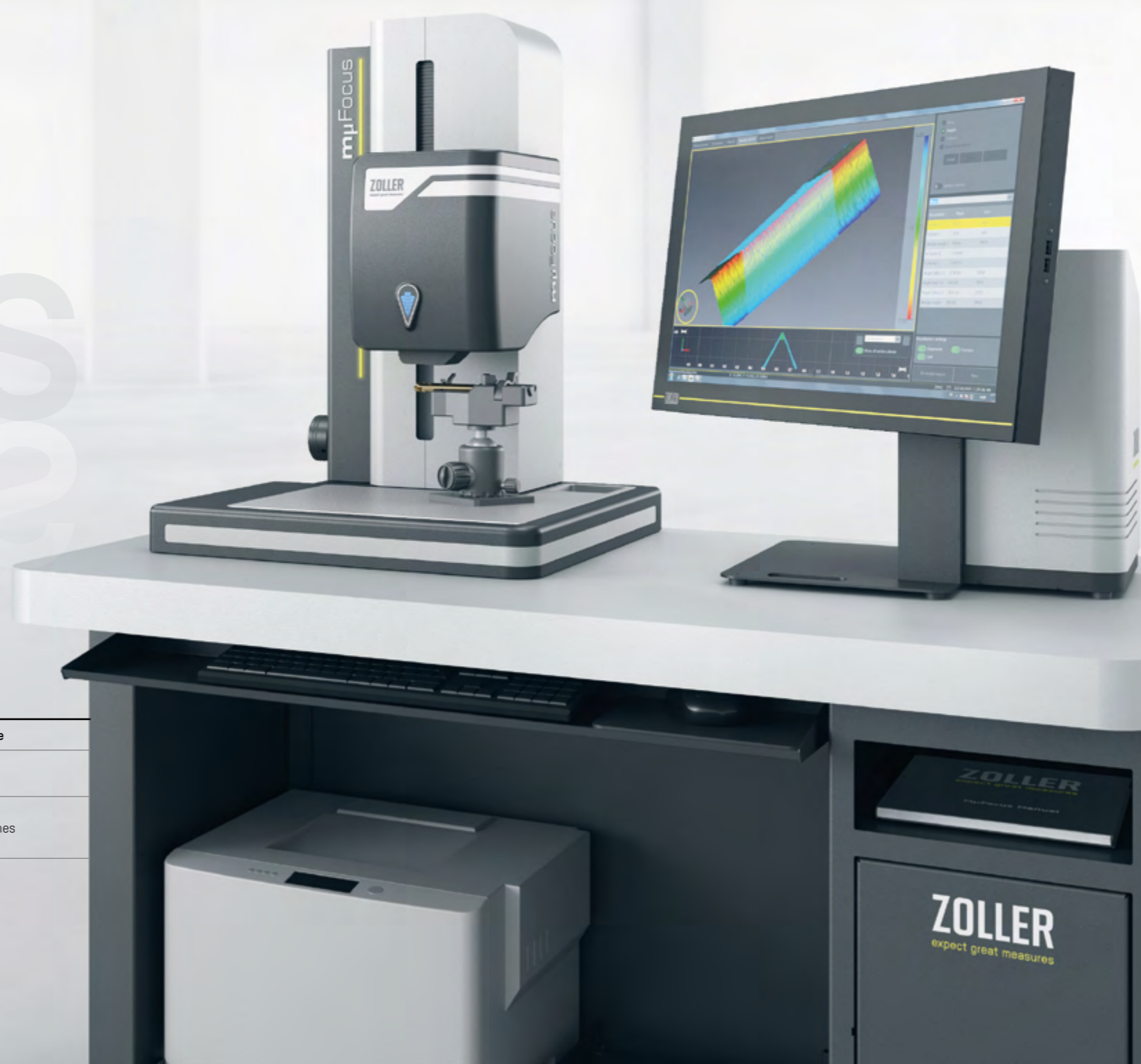
With ZOLLER, you can always rely on measurements that are precise down to the μm . » μ Focus« goes a step further. When analyzing surface roughness, it can measure with precision surpassing the μm threshold and achieve a measuring accuracy of $0.1 \mu\text{m}$. Thanks to the easy to use software and unique ergonomics, you can take advantage of this outstanding precision again and again.



» μ Focus« Overview

	Z axis	AA*	Measuring principle	Smallest measurable radius	Numerical aperture
»zep« sensor to measure cutting edge geometry 	300 mm / 11.8 inches	30 mm / 1.18 inches	Strip projection	3 μm	–
»zep-R« sensor for measuring 3D cutting edge geometry and surface roughness 	300 mm / 11.8 inches	20 mm / .79 inches	Confocal microscope	3 μm^{**}	0.42 mm / .02 inches

* AA describes the smallest distance between the lens and the measured object.

** Values for 20x lens; values for 50x lens: 1.4 μm .

We reserve the right to make technical changes. The depicted machines may include options, accessories, and control variants.



”

Markus Müllner, Measuring Technology Fitter at ZOLLER

Proud of »μFocus«

“For me, to assemble a »μFocus« is something special every single time. The machine combines two different characteristics you would not necessarily expect to go together: Although it is extremely heavy with a massive weight of 200 kilograms, it offers highly precise measuring technology that measures exactly, down to the μm .”

I install top-quality sensors and many other elements using modern technology into »μFocus« machines. I am very proud that installing the »μFocus« is one of my duties. I can promise you one thing: The »μFocus« is a seriously high-tech machine you can use to easily measure cutting edges and surfaces with outstanding precision.”

Turn the Extraordinary into a Matter of Habit

All of the functional and design elements, and all of the work processes performed by a ZOLLER » μ Focus« have been carefully shaped and selected. The results are clear for anyone developing cutting tools: Never before has it been so easy to achieve an outstanding inspection of cutting edge preparation and surface roughness, precise down to the μm .

Quick Manual Adjustment

Pre-positioning is fast, easy and convenient with quick adjustments. Upon request, » μ Focus« can even set the correct sensor position fully automatically using the optional CNC axis.

Measurement Sensor Variants

The blue symbol designates the machine version with the »zep« Edge Preparation Sensor. Use this version to measure cutting edge preparation quickly with high-precision accuracy.

The yellow symbol stands for the optional confocal microscope with the »zep-R« Edge Preparation Roughness Sensor. This sensor also analyzes surface roughness.

Multiple Tool Holders Available

You can use » μ Focus« for a wide range of different tools with the many optional tool holders available.

Manual Fine Setting of the Z Axis

Use the precise hand wheel to quickly and exactly set the sensor to the correct height after manual initial positioning, adjusting the focus level precisely to the desired area of the cutting edge.

Comprehensive Component Protection

The measuring technology and mechanisms of the » μ Focus« are reliably protected against moisture, dirt and dust. This ensures the machine has a long lifetime and allows it to be used directly in production. Specialized inspection rooms are not necessary.

The Most Modern Measuring Software

»pilot« machine software offers comprehensive convenience. The selection and input fields are easy to understand, all functions support efficient work, and the software offers multiple options to prepare measured values and display them in a clear way.

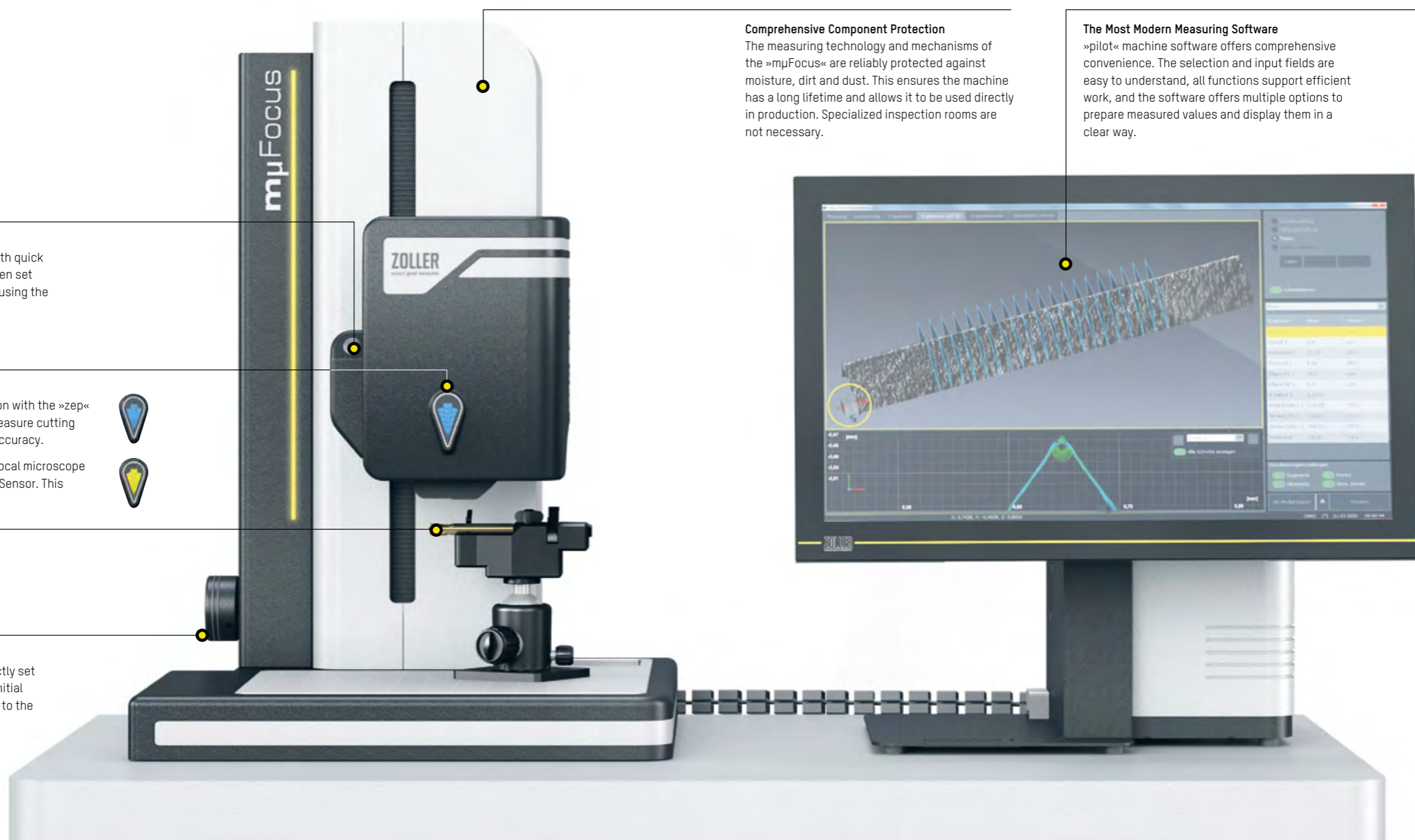

Ensures Optimal Positioning

To fully utilize the potential of the » μ Focus« software, you should securely clamp your tools and bring them to exactly the right position. ZOLLER offers optimal tool holders and accessories to help you perfectly position your tools for any measurement.



Spindle Mount

The spindle clamps tools using collets. The tool can be turned to any desired position for measurements



Mount for Indexable Inserts

The mount for cutting inserts can be tilted precisely in two axes to any position using two adjustment screws. This allows you to exactly position the inserts for measurement with » μ Focus«.



Cross Table

The optional cross table can also be used as a base for the tool holders, to precisely adjust them in two axes simultaneously.

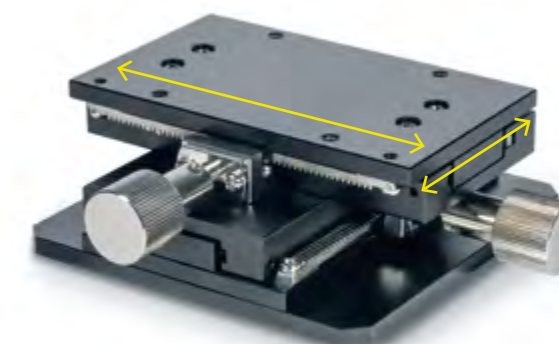

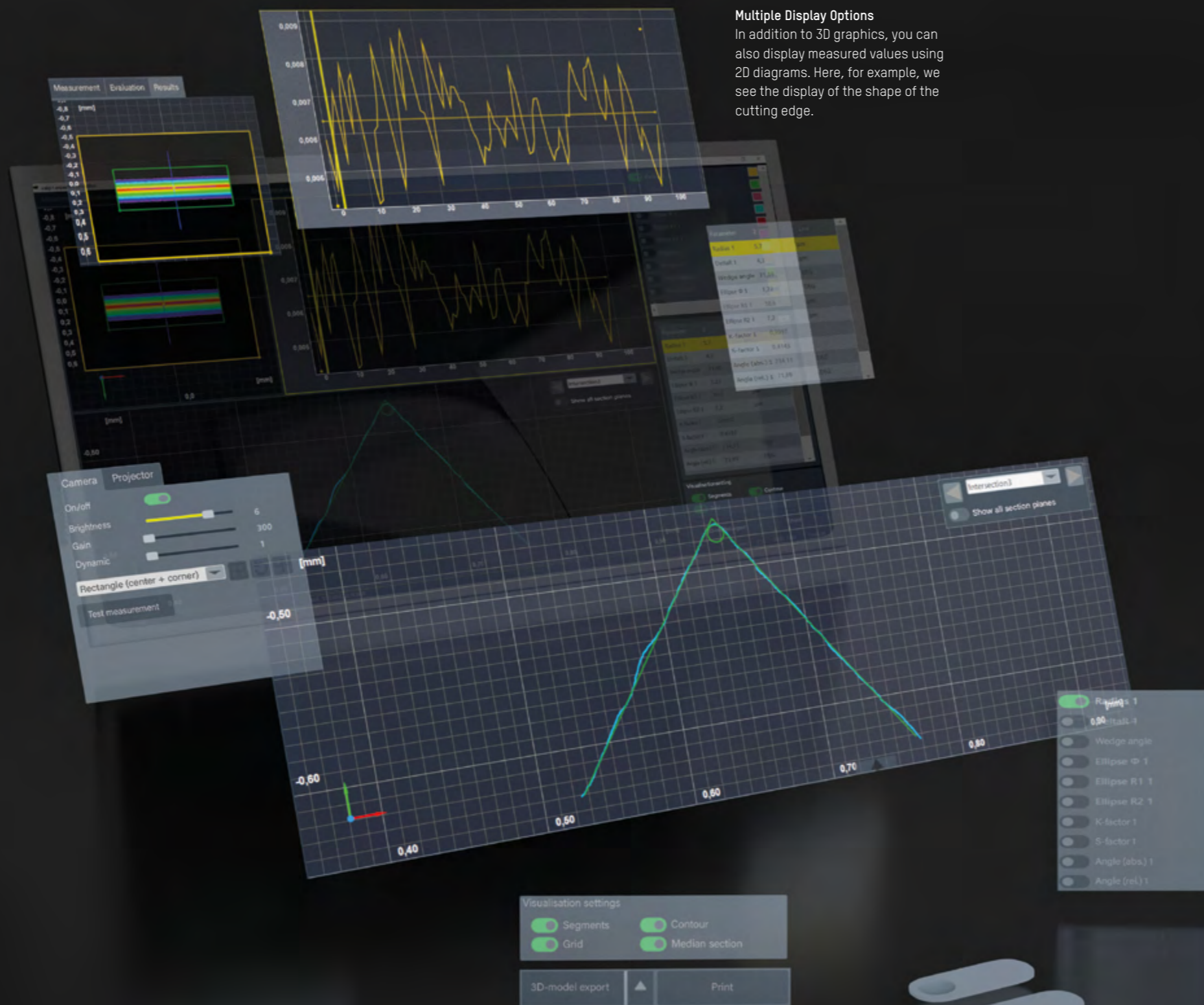

Multiple Display Options

In addition to 3D graphics, you can also display measured values using 2D diagrams. Here, for example, we see the display of the shape of the cutting edge.

Programmed for Efficiency

ZOLLER »pilot« measuring machine software is installed on all ZOLLER measuring machines – including »µFocus«. It ensures you receive precise measuring results and good repeatability in all measuring technology tasks, regardless of the operator. Interacting with the inspection machine and measured values is extremely easy. Users benefit from outstanding convenience in machine operation and analyzing measurement data.

Thanks to the flexible design of the software, ZOLLER can react even more quickly and efficiently to individual customer requirements for measuring tasks, analyses and evaluations.

Comprehensive Analysis Options

After completing a measurement, you can quickly use »pilot« to select the parameters you want to evaluate for the surface description.

Dialog Window Overview

»pilot« guides you through the measuring process, and supports you with a clear menu structure and easy to use dialog and input fields.

»pilot«

Guides You to the Finest Structures

ZOLLER » μ Focus« systematically approaches microstructures. Clear processes and supporting tools provide detailed insight of cutting tool edges and surfaces. You can detect wear quickly, create a 3D model with just one click, and easily measure cutting edge preparation and roughness.

» μ Focus« takes multiple individual images to record comprehensive raw data, then uses it to calculate a 3D model of the cutting edge. Then you can complete a standardized analysis of the measuring results and prepare them graphically using »pilot«.

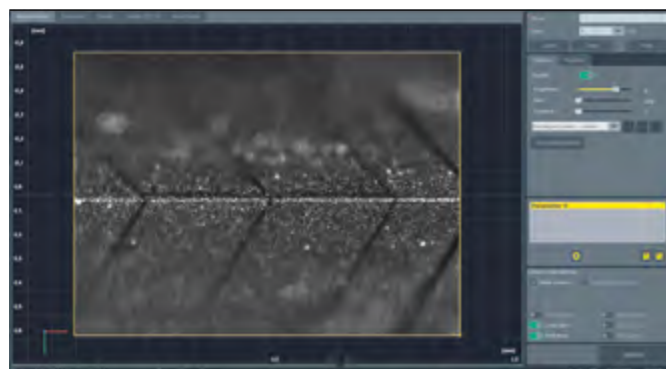

1. Easy to Focus

After you have clamped and positioned the tool, focus on the cutting edge. The monitor screen, adjustable lighting and software make focusing easy. Then you can select the measurement area and the parameters to be determined with a mouse click and start the measurement.

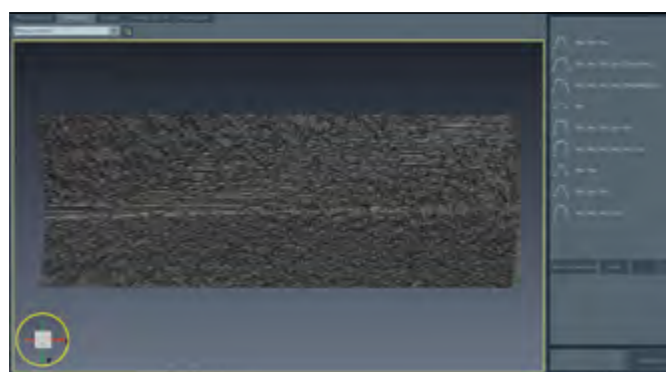

2. Individual Analysis

During the measurement, » μ Focus« scans the cutting edge and calculates a 3D model using DIN conform algorithms. You select the cutting edge geometry, and define how the software should analyze measuring results. You can specify, for example, how many sections should be created through the cutting edge. The more sections, the more precise your analysis will be.

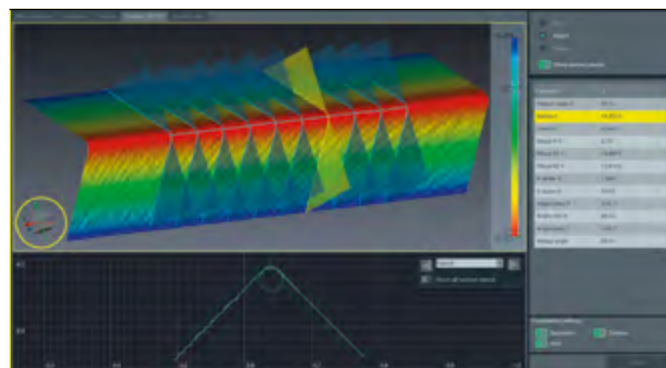

3. Versatile Displays

After completing the analysis, you can display measuring results topographically, in greyscale, as measurement curves, or in a table in accordance with DIN. The calculated 3D model can be colored, moved, turned and zoomed in any direction after visual inspection.

Ready for Different Geometry Types

You always have a choice, including different analysis options.

» μ Focus« can handle almost any kind of analysis, and shows a graphic display of shapes. Just click, start the analysis, and display your results.

With » μ Focus«, you gain an easy advantage in developing tool innovations.

Fast Selection, Fast Analysis

Large, clear symbols make it easy to make your selection. The cutting edge form Vec-Arc-Vec (line, arc, line) was identified in the example.

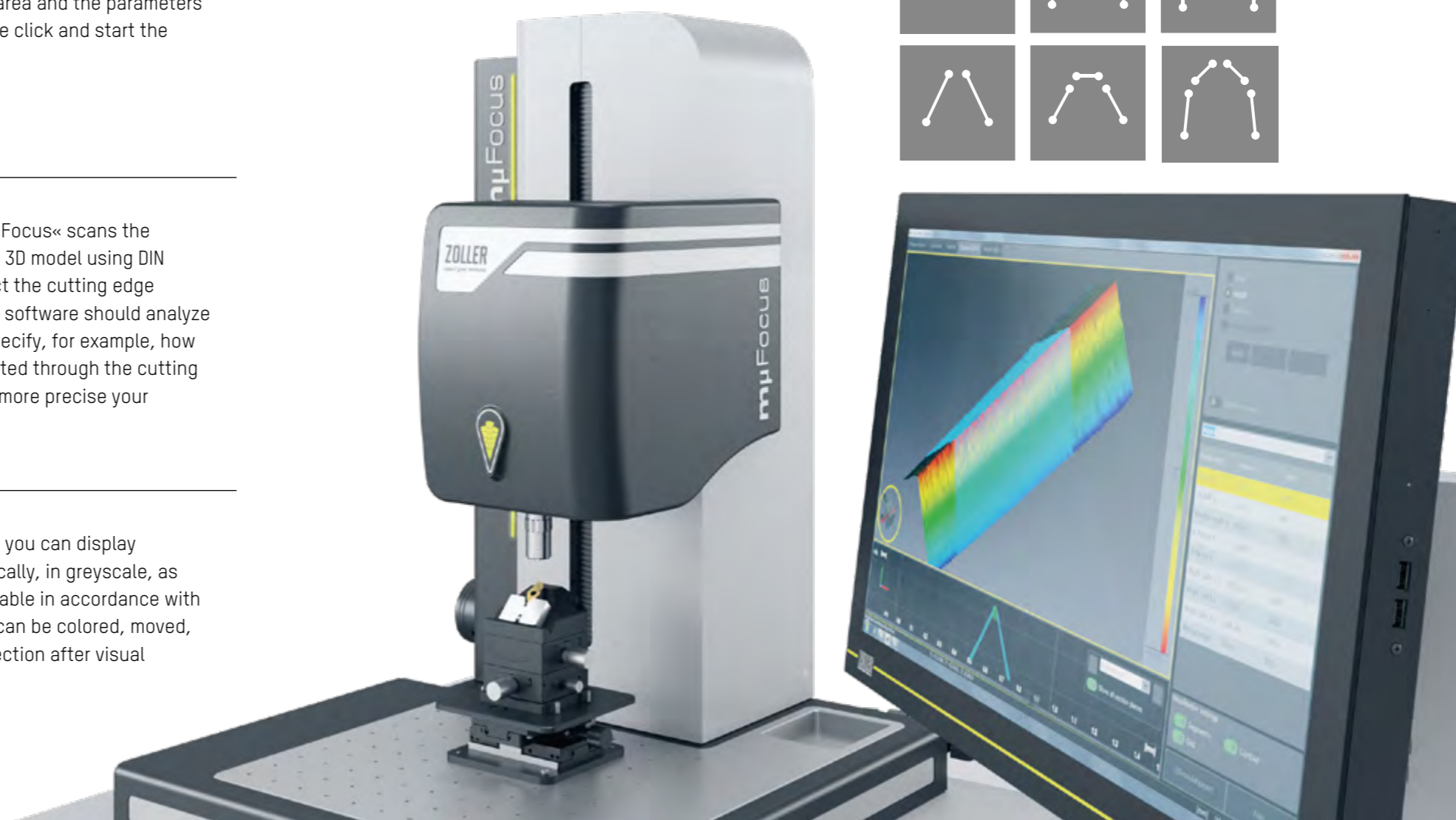
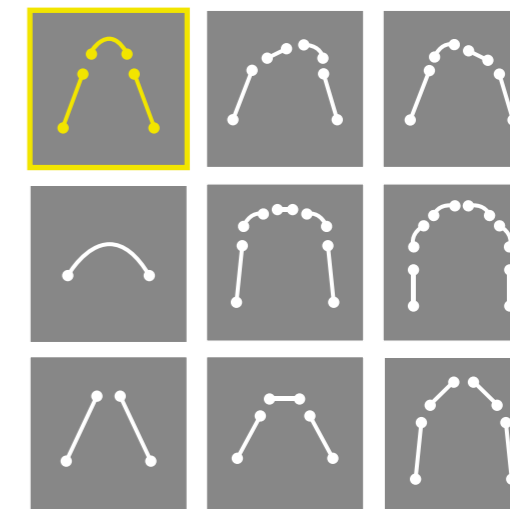

Detects Real Conditions

Tool surface roughness is an important criteria in determining the perfection of a tool. The ZOLLER » μ Focus« provides a precise display of surface roughness.

» μ Focus« uses raw data from the selected and scanned area to complete different analyses of the surface. It uses these to produce a corresponding profile, such as the Abbot curve, which can be used to display surface roughness.

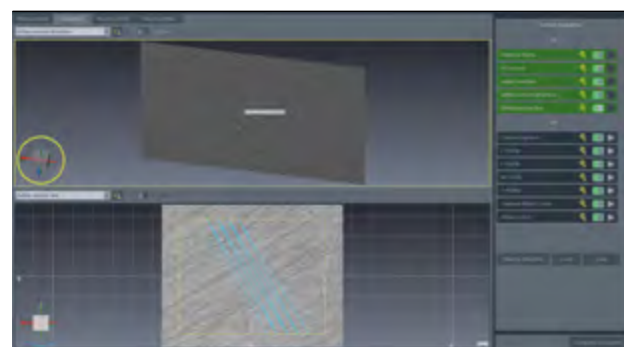

Information

» μ Focus« always shows you what it is doing, which parameters were selected, and which steps are currently in process. Completed process steps are highlighted in gray, while the measurement section is highlighted in color.

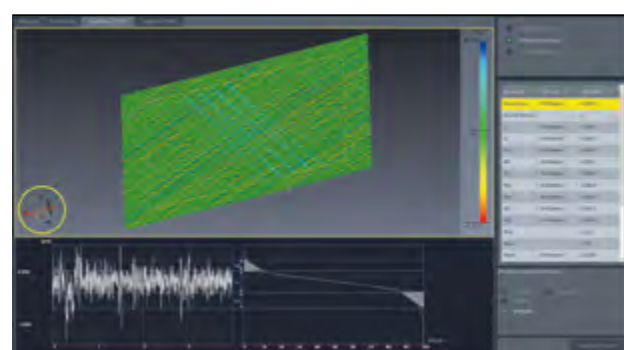

Topography

» μ Focus« displays the measured heights of the tool surface using color coding. The light blue line indicates the measurement section. Light blue and dark blue points mark lower areas, while yellow and red points mark elevated areas. In addition, the software displays an analysis as an Abbot curve.

Measured Values

If desired, you can display all measured values, parameters, and analyses as comprehensive tables.

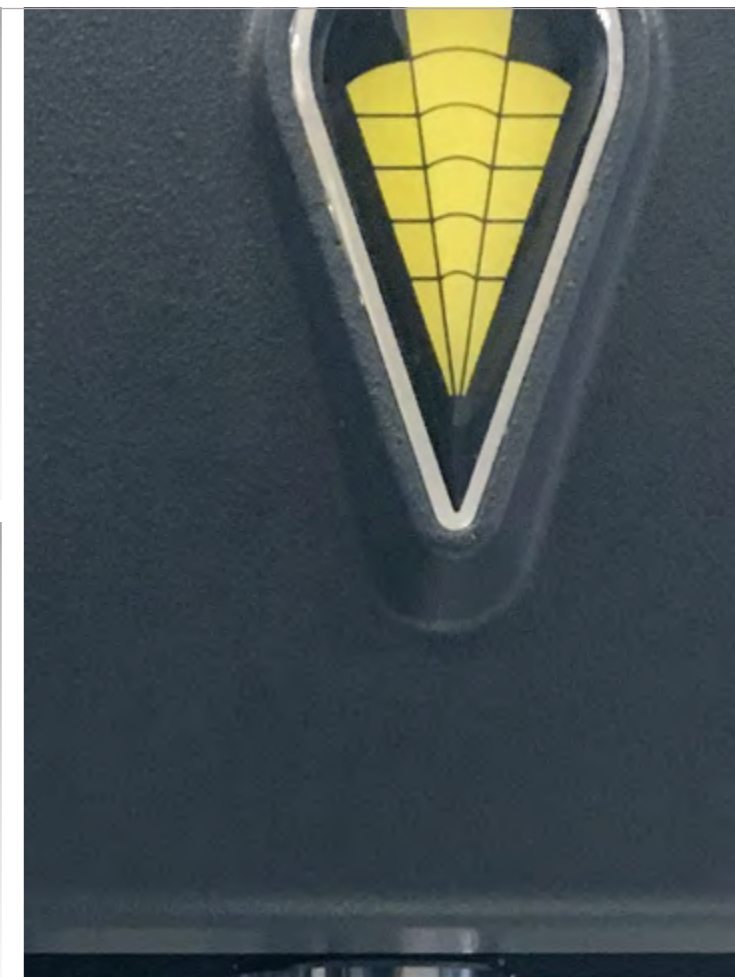
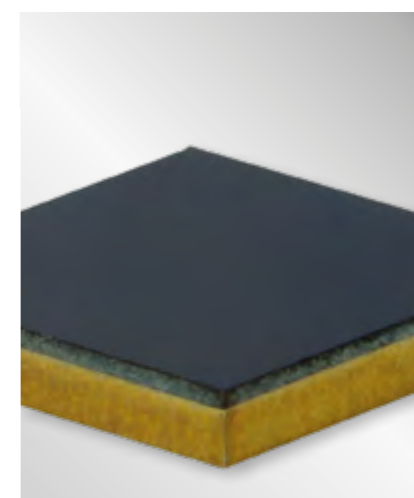
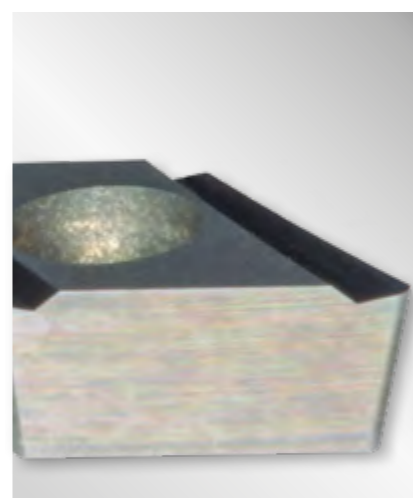
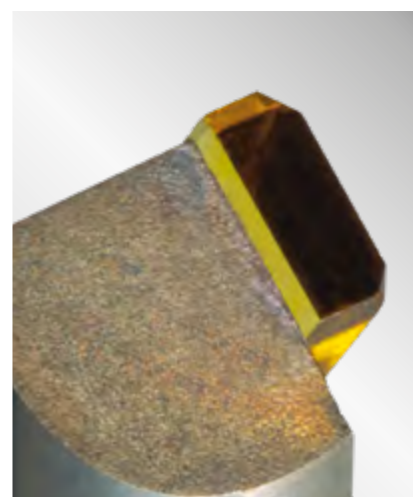

ISO Conforming for All Measured Variables

With ZOLLER, you can complete measurements in accordance with international standards such as ISO 4287 and ISO 13565. All measurements and analyses you complete with ZOLLER » μ Focus« are not only precise, but also standardized and comparable. You receive a broad range of measured variables you can use to describe and visualize cutting tool edges and surfaces.

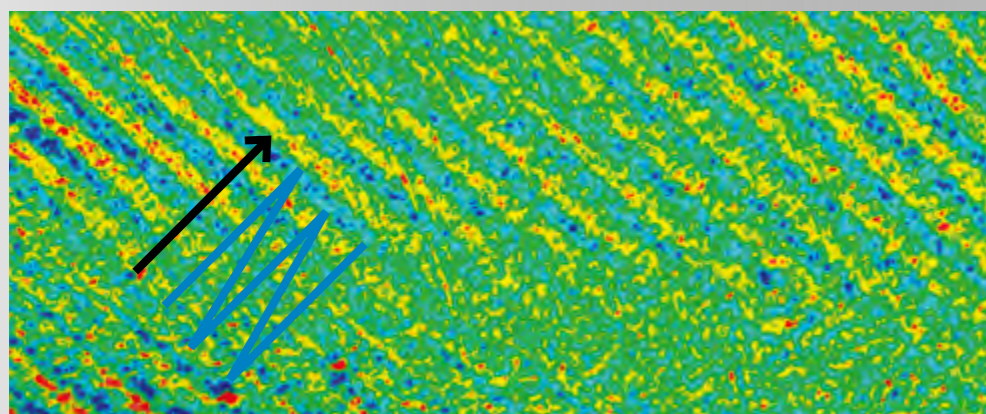

Display of grooves in a tool surface. Yellow points indicate elevated areas, while blue indicate recesses. The blue line marks the measurement path, while the arrow shows roughness orthogonal to the grooves.

How a ZOLLER » μ Focus« Analyzes Cutting Tool Edge Data

Surface Roughness:

The CCD camera records the surface structure of the measured area. The software then filters out blunders and errors from the data on the scanned surface, so that you can complete all analyses.

The analysis includes a color-coded height profile. Red points are closest to the »zep-R« sensor, while blue points are farthest away. The data is used to create a histogram. The histogram shows the distribution of the heights on the measured surface, and serves as the basis for all analyses.

Profile Roughness:

Height differences in the surface, their shape and their frequency must be detected to describe profile roughness. To do so, the software checks how these differences are distributed across the surface.

The image above clearly shows that the height difference on the tool surface creates a pattern of green surfaces and parallel yellow and blue lines. Yellow and red areas indicate elevated areas, while blue are recesses. The pattern shows the course of the grooves. Profile roughness is calculated vertically to the grooves (black arrow).

As in tactile measurement, the required minimum length is measured using visual measurements as well. The pixels are stitched together along the zig-zag shaped minimum distance in this small area.

Profile Roughness: Select Measurable Parameters in accordance with ISO 4287 and ISO 13565

- Ra: arithmetic mean deviation of the assessed profile
- Rq: root mean square deviation of the assessed profile
- Rt: total height of the roughness profile
- Rmax: maximum height of the roughness profile within an individual measured distance
- Rz: mean height of the roughness profile
- Rp: maximum profile peak height
- Rv: maximum profile valley depth
- Rk: core roughness depth
- Rpk: reduced peak height
- Rvk: reduced valley depth
- Mr1: material ratio delimiting the core area (Abbot curve)
- Mr2: material ratio delimiting the core area (Abbott curve)
- Rsm: mean spacing of profile elements
- R_{Pc}: Peak count number

Surface Roughness: Select Measurable Parameters in accordance with ISO 25178-2 and ISO 16610

- Sa: mean arithmetic height
- Sq: Root mean square height
- Sp: maximum peak height
- Sv: Maximum valley height
- Sz: maximum height
- S_{10z}: ten-point height of the surface
- Ssk: Skewness
- Sku: Kurtosis
- Sdq: Root mean square gradient
- Sdr: Developed interfacial area ratio
- FLTt: Evenness
- Sk: Level difference on core surface
- Spk: Reduced peak height
- Svk: reduced valley depth
- Smr1: Peak material portion
- Smr2: Valley material portion
- Vmc: Core material volume
- Vmp: Peak material volume
- Vvc: Core void volume
- Vvv: Dale void volume
- Sxp: Peak extreme height
- Str: Texture aspect ratio

Compact and Ergonomic

» μ Focus« is a machine offering compact dimensions and excellent ergonomics. Depending on the table design, it is optimized for seated or standing operation.



Two table options: Depending on which table you select, you can operate » μ Focus« at a seated or standing work station. When equipped with a »zep« sensor, » μ Focus« is also available as a simple table top machine (without a table system).

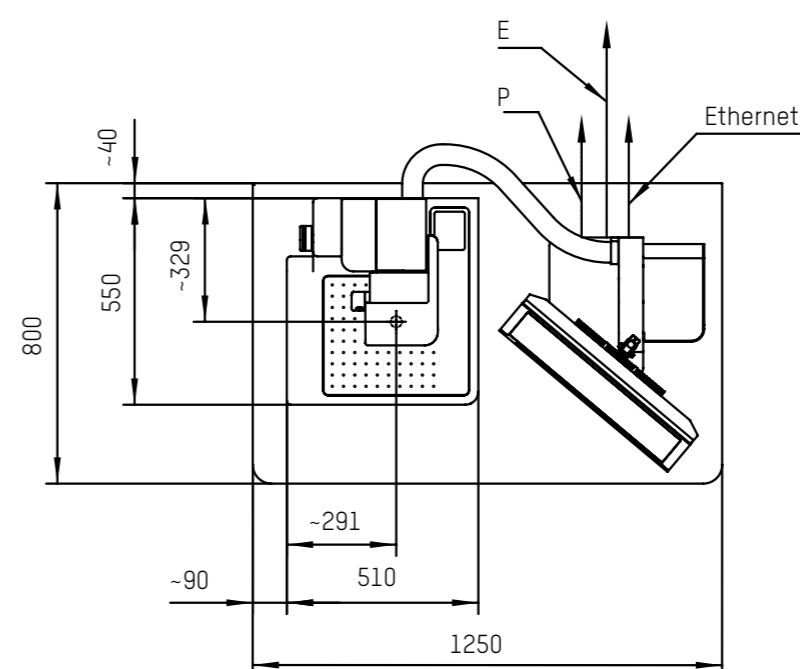
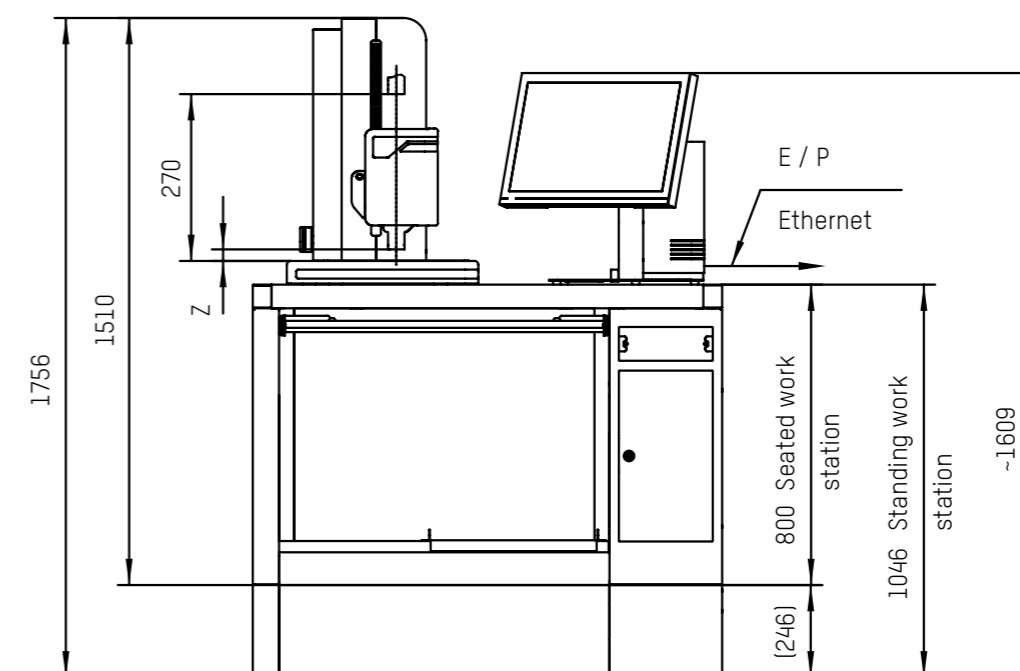

Note: P: Air connection E: Electrical connection

Installation weights

Measuring machine	Weight
» μ Focus« with »zep« sensor and table system	250 kg
» μ Focus« with »zep-R« sensor and table system	270 kg
» μ Focus« with »zep« sensor, without table system	75 kg

At home in Germany – around the world for you

- Parent company
- Headquarters
- Branch office
- Representative

ZOLLER quality is “Made in Germany” – and there for you, everywhere in the world.

Our company has a global presence with 85 site locations made up of our own branches and representatives network. This guarantees you receive first-class, personalized customer service in every corner of the world.

GERMANY

HEADQUARTERS

E. Zoller GmbH & Co. KG
 Presetting and measuring machines
 Gottlieb-Daimler-Straße 19
 D-74385 Pleidelsheim
 Tel: +49 7144 8970-0
 Fax: +49 7144 8060-807
 post@zoller.info | www.zoller.info

ZOLLER NORTH

E. Zoller GmbH & Co. KG
 Service and Sales Center
 D-30179 Hanover

ZOLLER EAST

E. Zoller GmbH & Co. KG
 Service and Sales Center
 D-04158 Leipzig

ZOLLER WEST

E. Zoller GmbH & Co. KG
 Service and Sales Center
 D-40764 Langenfeld

AMERICA

USA

ZOLLER Inc.
 North American Headquarters
 USA-48108 Ann Arbor, MI
 sales@zoller-usa.com | www.zoller-usa.com

ZOLLER Inc. Pacific
 USA-90503 Torrance, CA
 sales@zoller-usa.com | www.zoller-usa.com

CANADA

ZOLLER Canada Inc.
 CAN-LSN 8G4 Mississauga, ON
 sales@zoller-canada.com | www.zoller-canada.com

MEXICO

ZOLLER Tecnologías S de R.L. de C.V.
 MEX-C.P. 76030 Col. San Angel Querétaro
 Estado de México
 sales@zoller-mexico.com | www.zoller-mexico.com

Brazil

ZOLLER do Brasil
 Nova Vinhedo, Vinhedo - Sao Paulo CEP 13284-198
 comercial@zoller-br.com | www.zoller.info

EUROPE

AUSTRIA

ZOLLER Austria GmbH
 A-4910 Ried im Innkreis
 office@zoller-a.at | www.zoller-a.at

SWITZERLAND

ZOLLER Schweiz GmbH
 CH-9016 St. Gallen
 buehler@zoller-ch.com | www.zoller-ch.com

FRANCE

ZOLLER France
 F-67380 Lingolsheim
 info@zoller.fr | www.zoller.fr

SPAIN + PORTUGAL

ZOLLER Ibérica S.L.
 E-08006 Barcelona
 correo@zoller.info | www.zoller.info

TURKEY

Zoller Ölçüm Teknolojileri San.ve Tic. Ltd. Sti.
 TR-16120 Nilüfer / Bursa
 info@zoller-tr.com | www.zoller-tr.com

RUSSIA

LLC ZOLLER Russia
 RU-111123 Moscow, Russia
 info@zoller-ru.com | www.zoller-ru.com

ISRAEL

ZOLLER Israel
 Haifa, Israel
 info@zoller-il.com | www.zoller.info

ASIA

INDIA

ZOLLER India Private Ltd.
 IN-Pune 411019 Maharashtra, India
 info@zoller-in.com | www.zoller-in.com

CHINA

ZOLLER Shanghai, Ltd.
 Asia Pacific Regional Headquarters
 RC-201108 Shanghai
 info@zoller-cn.com | www.zoller-cn.com

ZOLLER Asia Pacific, Ltd.

RC-Kowloon, Hong kong
 info@zoller-cn.com | www.zoller-cn.com

JAPAN

ZOLLER Japan K. K.
 JP-564-0033 Osaka, Japan
 info@zoller-jp.com | www.zoller-jp.com

THAILAND

ZOLLER (Thailand) Co. Ltd.
 Amphur Muang Chonburi, TH-20000 Thailand
 info@zoller-in.com | www.zoller-th.com

INDONESIA

ZOLLER Singapore Pte. Ltd
 Indonesia Representative Office
 ID-Serpong – Tangerang 15325, Indonesia
 info@zoller-in.com | www.zoller-in.com

MALAYSIA

ZOLLER MALAYSIA SDN. BHD.
 Malaysia Representative Office
 MY-Petaling Jaya | Selangor Darul Ehsan, Malaysia
 lau@zoller-my.com | www.zoller-in.com

VIETNAM

ZOLLER Vietnam
 VNM-Ho Chi Minh City, Vietnam
 info@zoller-in.com | www.zoller-in.com

KOREA

ZOLLER Korea Co., Ltd.
 KOR-15119 - Siheung-Si, Gyeonggi-Do, South Korea
 info@zoller-kr.com | www.zoller-kr.com

REPRESENTATIVES

Belgium, Bulgaria, Denmark, Estonia, Finland, Great Britain, Ireland, Italy, Croatia, Latvia, Lithuania, The Netherlands, Norway, Poland, Romania, Sweden, Slovakia, Slovenia, South Tiro, the Czech Republic, Ukraine, Hungary, Belarus, Argentina, Chile, Colombia, Peru, South Africa, Australia, Pakistan, Taiwan, United Arab Emirates



ZOLLER

Solutions

More speed, higher quality, safer processes – with ZOLLER you can get more out of your production.

We combine hardware, software and services to give you optimum system solutions for presetting, measuring, inspection and managing machining your cutting tools.

Presetting & Measuring

Tool Management

Inspection & Measuring

Automation

Everything from a single supplier.
Everything for your success.
Everything with ZOLLER solutions.

ZOLLER
expect great measures

Headquarters in Pleidelsheim

E. ZOLLER GmbH & Co. KG

Tool presetter and measuring machines

Gottlieb-Daimler-Straße 19 | D-74385 Pleidelsheim

Phone: +49 7144 8970-0 | Fax: +49 7144 8970-701917

post@zoller.info | www.zoller.info