

## Adapter SK50 / VDI-straight shank

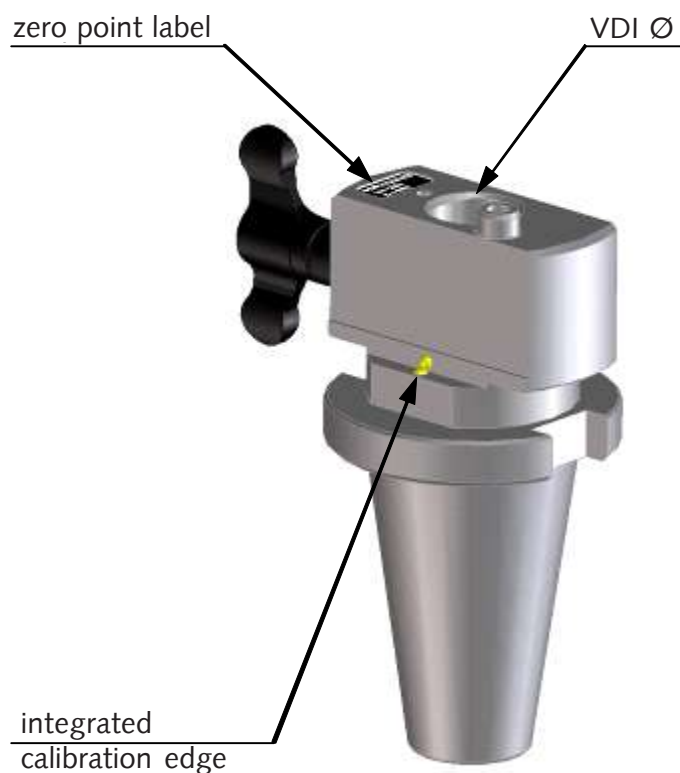

- for holding fixture of tools with VDI-straight shank DIN 69880
- manual tool holder clamping
- integrated calibration edge
- case-hardened, gunmetal finish and ground

VDI Size Ø	standard item no.	"Z" <sup>1)</sup> in mm	weight in kg	driven tool holders item no.	"Z" <sup>1)</sup> in mm	weight in kg
16	6 300 016	80	4,10	6 300 016	80	4,10
20	6 300 020	80	4,10	6 300 020	80	3,95
25	6 300 025	80	3,90	6 300 025	80	3,90
30	6 302 030	85	3,75	6 302 030	85	3,75
40	6 300 040	85	4,50	6 302 040	115	4,80
50	6 300 050	95	4,90	6 302 050	125	5,60
60	6 300 060	105	5,60	6 302 060	125	6,50
80	6 301 080 *	175	11,00	-	-	-

<sup>1)</sup> loss in measuring length „Z“.

\* additional costs / special size (please ask for price).